

RB-KAIROS 3

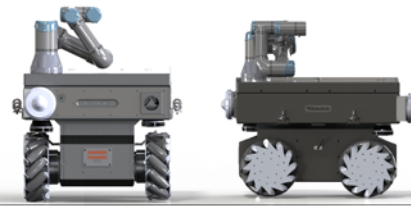

COMPLETELY INTEGRATED
**COLLABORATIVE MOBILE
MANIPULATOR (CMM)**, FOR
INDUSTRIAL TASKS

INDUSTRIAL MOBILE MANIPULATION

PICK & PLACE
LOADING / UNLOADING
POSITIONING OF WORKPIECES
ASSEMBLY
SCREWING
DRILLING / MILLING
INSPECTION AND CHECK
RESEARCH & DEVELOPMENT



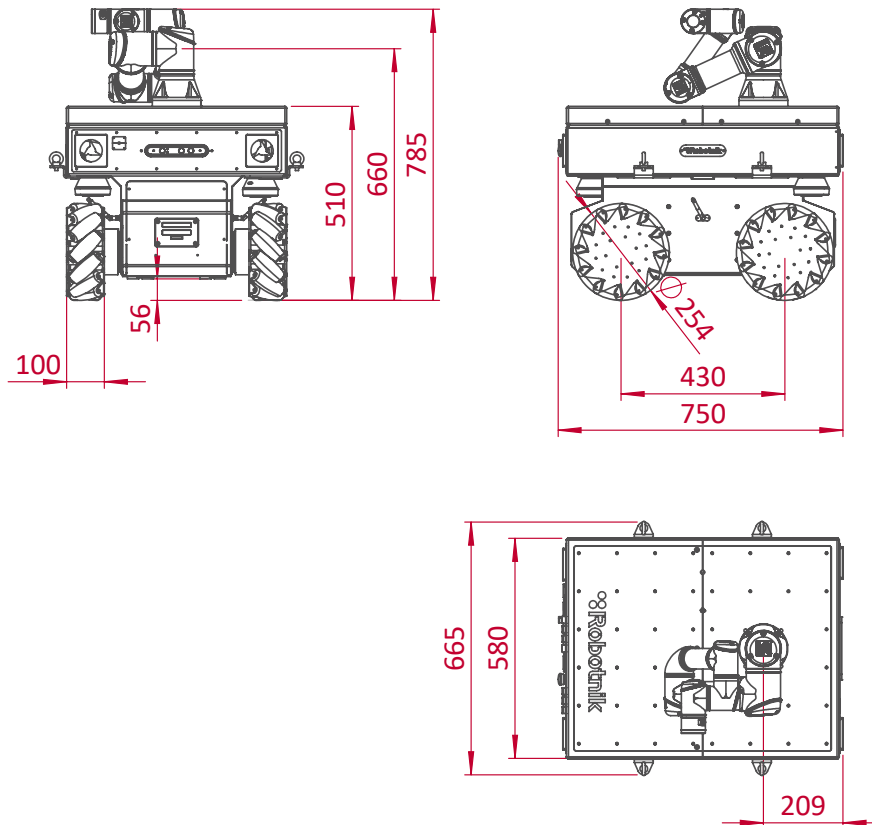

TECHNICAL SPECIFICATIONS

MECHANICAL

(Configuration with omnidirectional wheels)

Dimensions **750 x 665 x 785 mm (Folded)**

Weight **115 kg**

Payload **115/250 kg**

Speed **2 m/s**

Environment **Indoor**

Enclosure class **IP54**

Autonomy **6/12 h continuous motion**

Batteries **LiFePO₄ 15/30Ah@48V**

Traction motors **4 x 500 W brushless servomotors**

Temperature range **0° to +50°C**

Max. slope **25 %**

CONTROL

Controller **Open architecture ROS
Integrated PC with Linux**

Communication **WiFi 802.11n**

Connectivity **Internal: USB, RS232 and GPIO
External: USB, RJ45, power
supplies 5, 12 VDC and battery**

ARM

Weight **11 kg**

Payload **3 kg**

Reach **500 mm**

EGP 40 CO ACT

(Optional gripper)

Weight **0,7 kg**

Gripping force **35-140 N**

Stroke **6 mm**