

RB-KAIROS+



MOBILE PLATFORM
READY TO **INTEGRATE A URE ARM**
(UR3/UR5/UR10/UR16)

INDUSTRIAL APPLICATIONS

LOGISTICS

SURVEILLANCE & MONITORING

RESEARCH & DEVELOPMENT



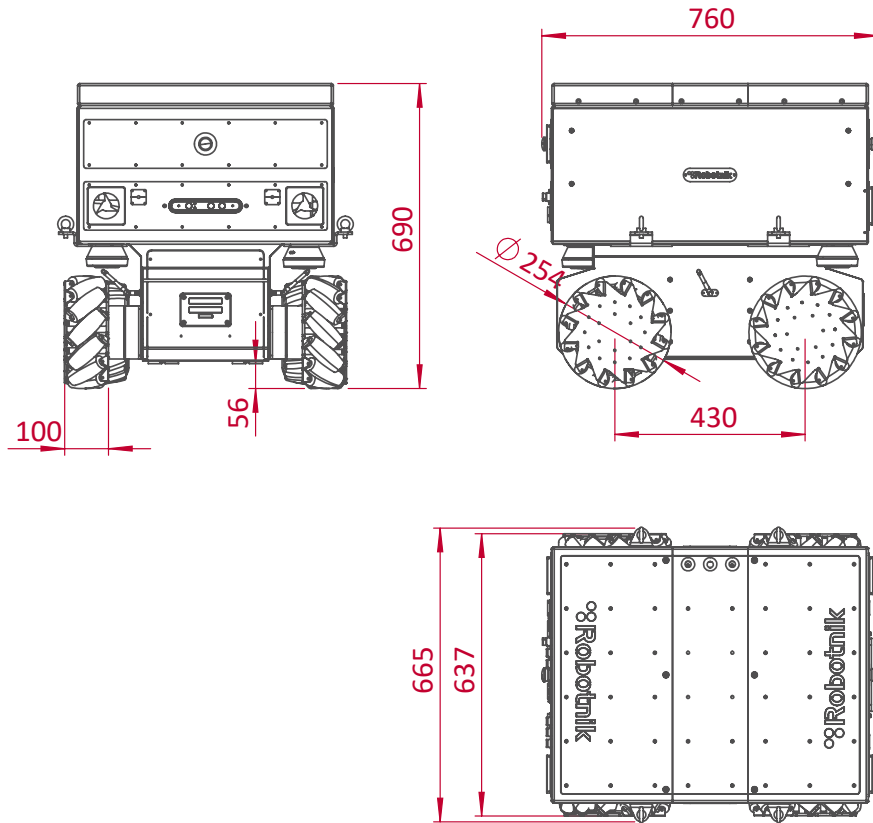

TECHNICAL SPECIFICATIONS

MECHANICAL

Dimensions	760 x 665 x 690 mm
Weight	115 kg
Payload	250 kg
Speed	2 m/s
Environment	Indoor
Enclosure class	IP54
Autonomy	6/12 h continuous motion
Batteries	LiFePO₄ 15/30Ah@48V
Traction motors	4 x 500 W brushless servomotors
Temperatura range	0° to +50°C
Max. slope	10 %

CONTROL

Controller	Open architecture ROS Integrated PC with Linux
Communication	WiFi 802.11n
Connectivity	Internal: USB, RS232 y GPIO External: USB, RJ45, power supplies 5, 12 VDC and battery Ready for plug and play integration of Universal Robots™ arms