

# RB-KAIROS



## MOBILE PLATFORM

READY TO INTEGRATE A UR e-SERIES  
ARM (UR3e/UR5e/UR10e/UR16e)

PICK & PLACE  
METROLOGY  
PART FEEDING  
INDUSTRIAL APPLICATIONS  
R & D



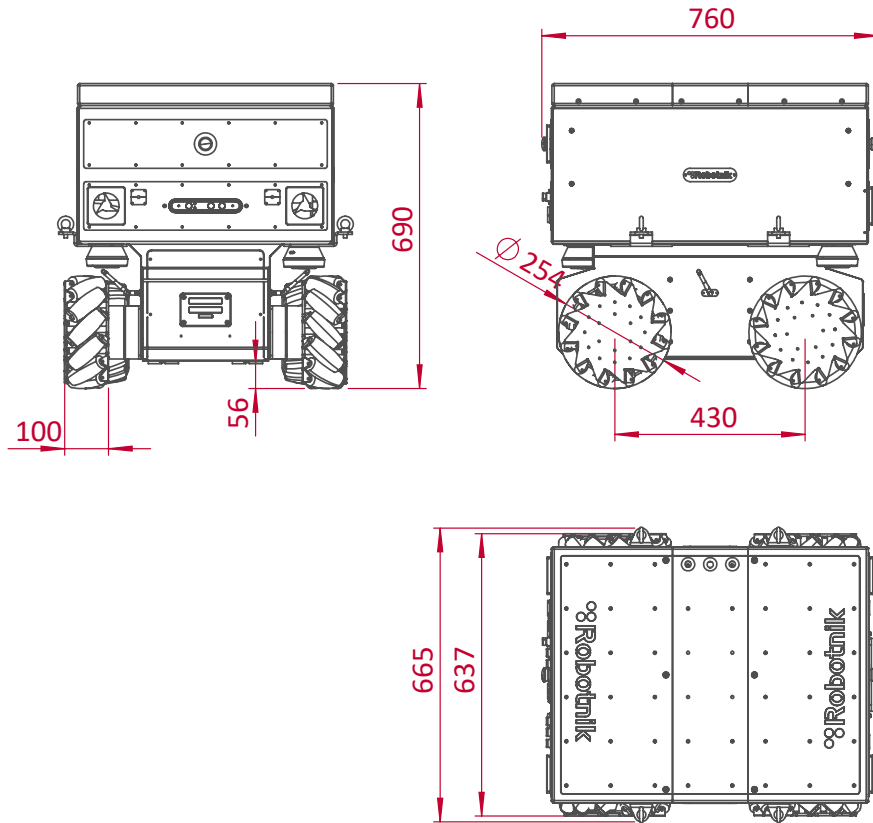

## TECHNICAL SPECIFICATIONS

### MECHANICAL

Dimensions	<b>760 x 665 x 690 mm</b>
Weight	<b>115 kg</b>
Payload	<b>250 kg</b>
Speed	<b>2 m/s</b>
Environment	<b>Indoor</b>
Enclosure class	<b>IP54</b>
Autonomy	<b>6/12 h continuous motion</b>
Batteries	<b>LiFePO<sub>4</sub> 15/30Ah@48V</b>
Traction motors	<b>4 x 500 W brushless servomotors</b>
Temperatura range	<b>0° to +50°C</b>
Max. slope	<b>10 %</b>

### CONTROL

Controller	<b>Open architecture ROS Integrated PC with Linux</b>
Communication	<b>WiFi 802.11n</b>
Connectivity	<b>Internal: USB, RS232 y GPIO External: USB, RJ45, power supplies 5, 12 VDC and battery</b>
	<b>Ready for plug and play integration of Universal Robots™ arms (OEM DC Version)</b>