

# RB-VOGUI-6

AUTONOMOUS MOBILE ROBOT (AMR)



---

INDOOR & OUTDOOR  
**LOGISTICS APPLICATIONS**  
VERSATILITY & **HIGH MOBILITY**

---

INDUSTRIAL APPLICATIONS  
AGRICULTURE  
MILITARY  
ORDER PREPARATION DELIVERY  
PICKING & TRANSPORT



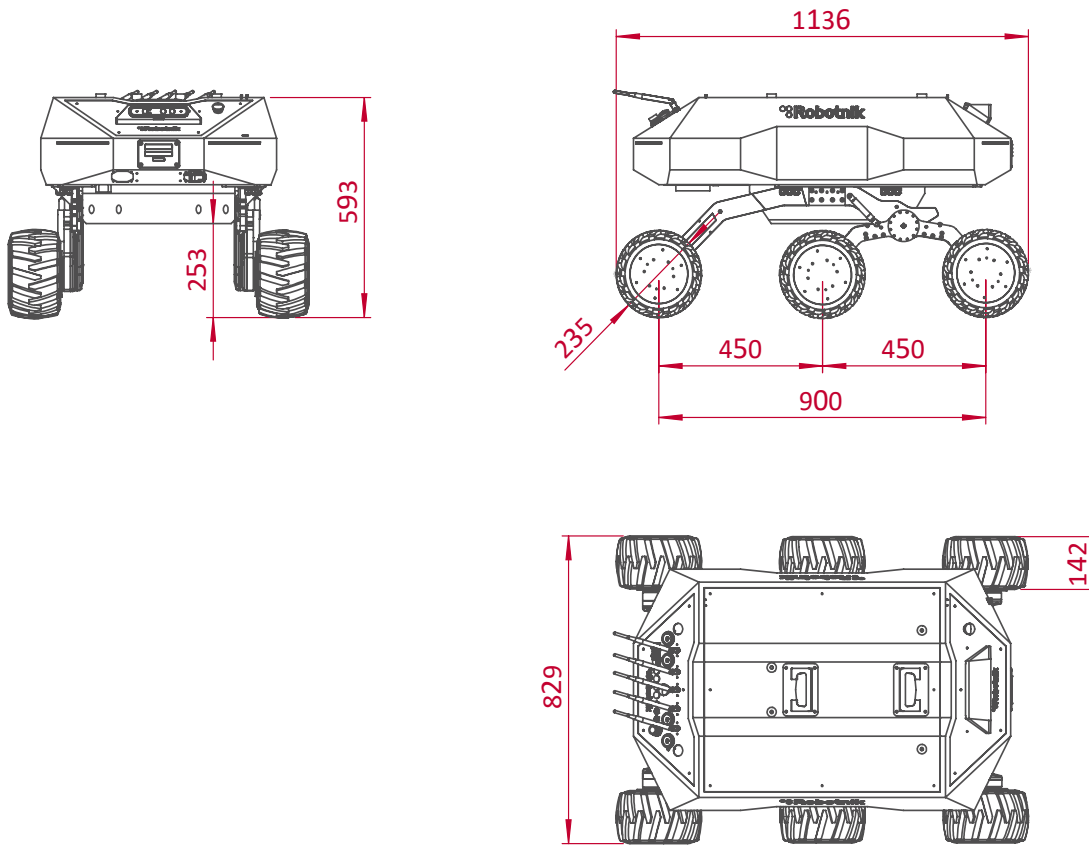

## TECHNICAL SPECIFICATIONS

### MECHANICAL

Dimensions	<b>1.136 x 829 x 593 mm</b>
Weight	<b>142 Kg</b>
Speed	<b>2,5 m/s</b>
Environment	<b>Indoor / Outdoor</b>
Autonomy	<b>Up to 7 h</b>
Batteries	<b>LiFePO4 30Ah@48V</b>
Traction motors	<b>6 x 500 W</b>
Temperature range	<b>-10°C to +45°C</b>
Payload	<b>Up to 150 Kg</b>
Max. Slope	<b>47 %</b>

### CONTROL

Controller	<b>Open architecture ROS Integrated PC with Linux</b>
Communication	<b>WiFi 802.11n</b>
Connectivity	<b>Internal: USB, RS232, RJ45 External: 2x USB, 2x RJ45, 1x hdmi + USD, 5, 12 y 48v power supplies</b>