

# RB-VOGUI XL

AUTONOMOUS MOBILE ROBOT



INDOOR & OUTDOOR  
**LOGISTICS APPLICATIONS**

**HIGH VERSATILITY  
& MOBILITY**

INDUSTRIAL APPLICATIONS  
RESEARCH & DEVELOPMENT  
PICKING & TRANSPORT  
AGRICULTURE  
MILITARY



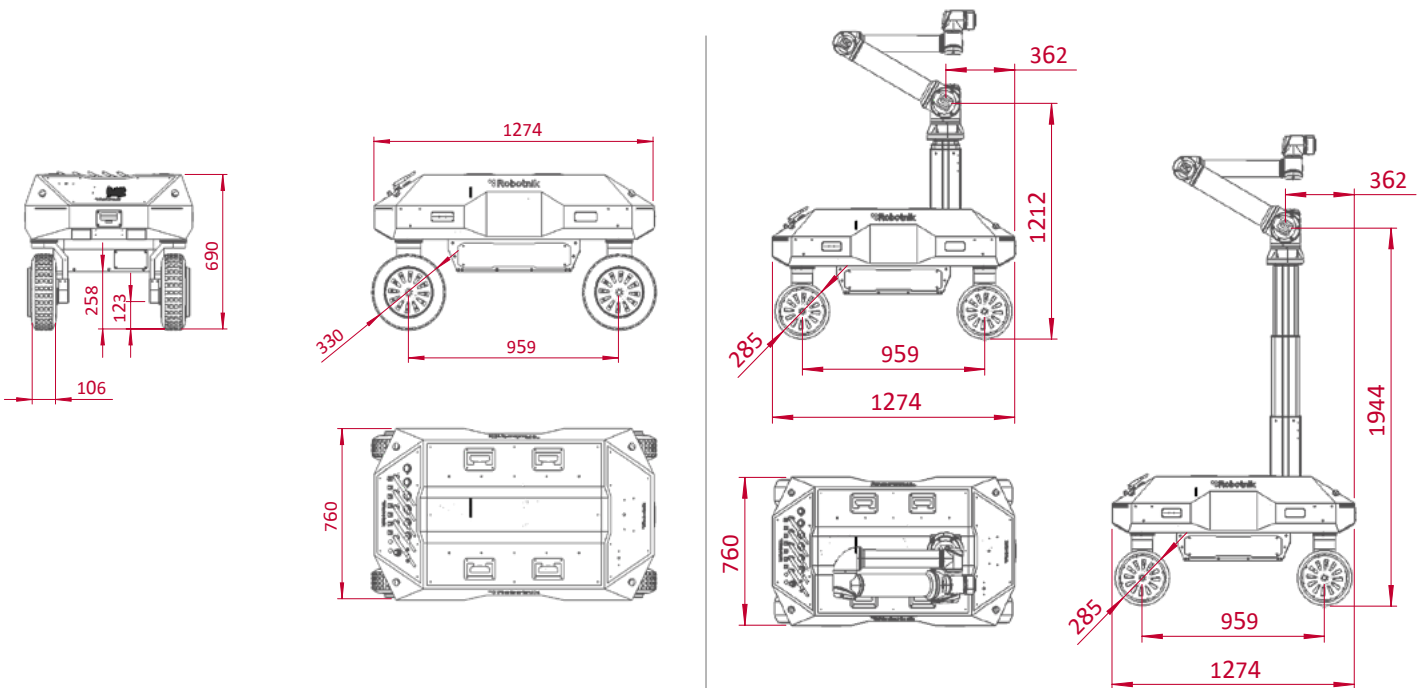

## TECHNICAL SPECIFICATIONS

### MECHANICAL

Dimensions	<b>1.274 x 760 x 690 mm</b>
Weight	<b>250 kg</b>
Speed	<b>1 m/s</b>
Environment	<b>Indoor / Outdoor</b>
Autonomy	<b>Up to 5 h</b>
Batteries	<b>LiFePO<sub>4</sub> 60Ah@48V</b>
Traction motors	<b>4 x 750 W</b>
Steering motors	<b>2 x 200 W Ackermann 4 x 200 W OMNI 4</b>
Temperature range	<b>-10°C to +45°C</b>
Payload	<b>Up to 200 Kg</b>
Max. Slope	<b>47 %</b>

### CONTROL

Controller	<b>Open architecture ROS Integrated PC with Linux</b>
Communication	<b>WiFi 802.11n</b>
Connectivity	<b>Internal: USB, RS232, RJ45 External: 2x USB, 2x RJ45, 1X hdmi + USD, 5, 12 VDC and 48v power supplies</b>

### URIOE

Payload	<b>10 kg</b>
Reach	<b>1.300 mm</b>

**Ready for integration of compatible accessories arm available in ROS Components store**