

CROM

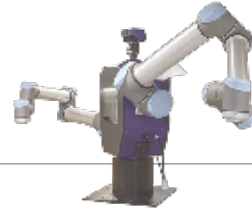

AN UPPER BODY ROBOT
INTENDED FOR **RESEARCH
IN MANUFACTURING
ENVIRONMENTS**

IT REQUIRES NO SAFETY
CAGES & IS SAFE TO **OPERATE
DIRECTLY NEXT TO PEOPLE**

RESEARCH & DEVELOPMENT
OF HUMAN ROBOT INTERACTION
IN MANUFACTURING ENVIRONMENTS

ADVANCED PERCEPTION &
MANIPULATION TASKS

INDUSTRIAL HUMANOIDS

ARTIFICIAL INTELLIGENCE

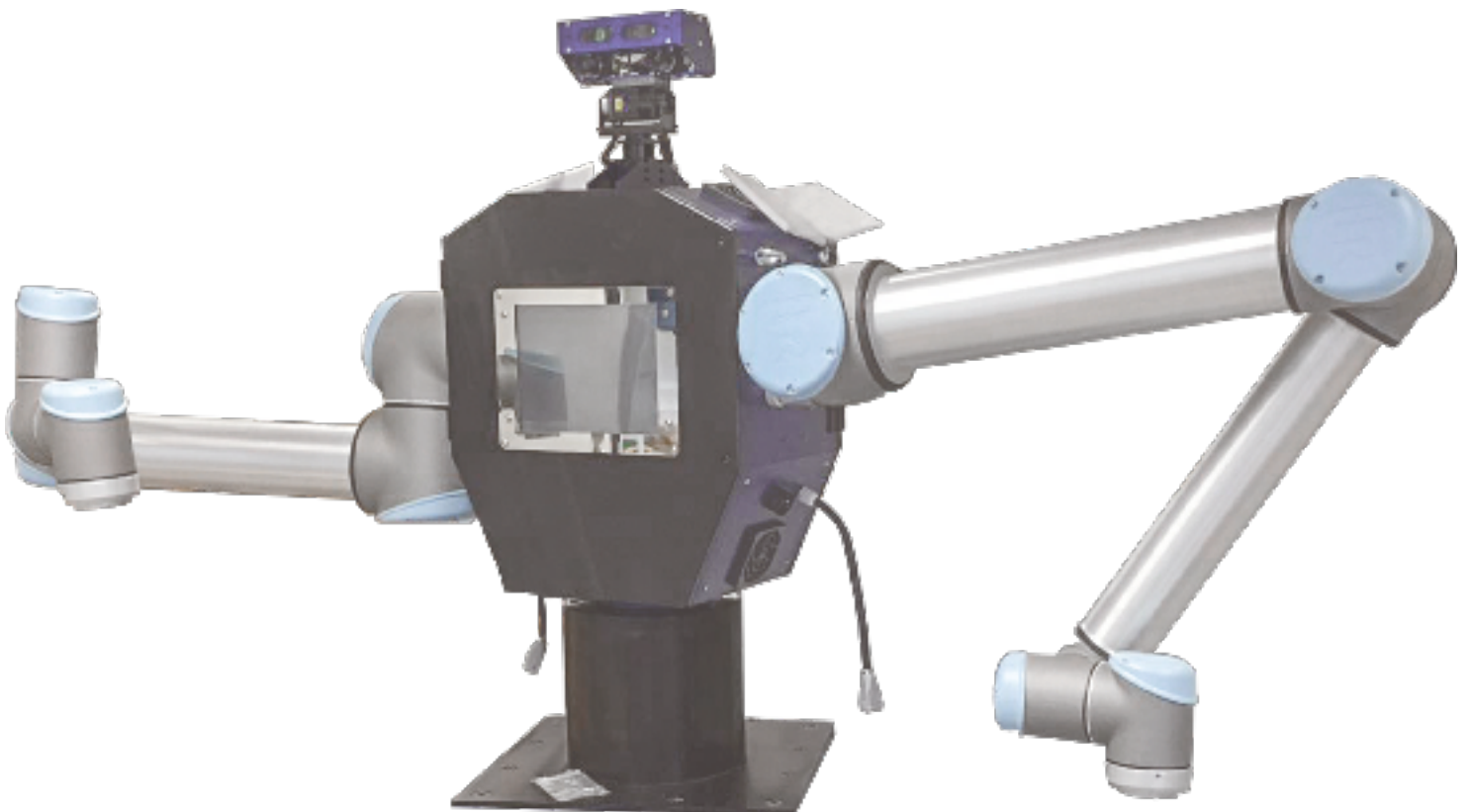

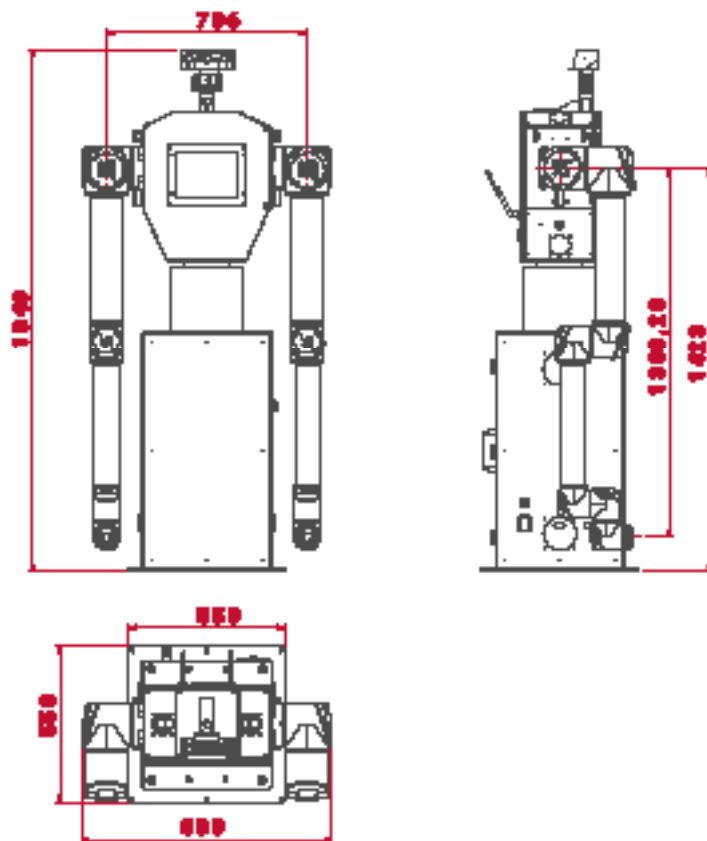

TECHNICAL SPECIFICATIONS

MECHANICAL

Dimensions **1.840 x 880 x 550 mm**

Total mass **Approx 105 Kg**

Exterior structure **Frame structure: aluminium alloy cast metal**

Degrees of freedom (axes) **15 axes**

Joints **Head: 2 axes (pitch and yaw)
Arm: 6 axes
Waist: 1 axis (yaw)**

Additional devices **Hand (8 axes)
Gripper (1 axis)
Frontal screen
Perception devices (head camera x 2, hand camera x 2, 3D sensor x 1)**

Power supply **220VAC, 10A**

CONTROL

Operating System **Ubuntu 12.04, 14.04**

Interface **LAN port (100 base-T) x 1, Axis control via CAN bus**

ROBOT SOFTWARE

Control **ROS (Robot Operating System)
MoveIt**

Operation mode **Point-to-point motion control of all axes, (linear) cartesian trajectories of each arm, being possible to define different TCPs (Tool Center Points), Euler angles trajectories of both arms.**