

# SUMMIT-XL STEEL

AUTONOMOUS MOBILE ROBOT (AMR)



MOBILE ROBOT WITH A  
MECHANICAL STEEL STRUCTURE  
THAT ALLOWS **CARRYING HEAVY  
LOADS UP TO 250 KG**

INDUSTRIAL APPLICATIONS

LOGISTICS

SURVEILLANCE & MONITORING

RESEARCH & DEVELOPMENT



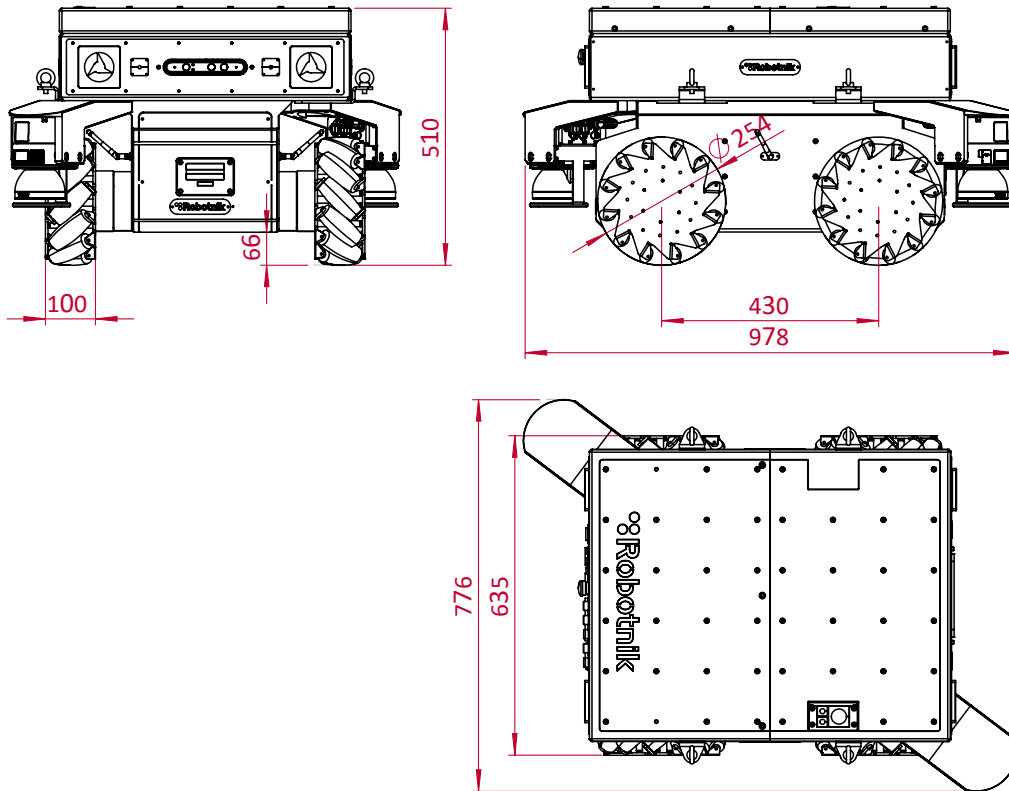

## TECHNICAL SPECIFICATIONS

### MECHANICAL

Dimensions	<b>978 x 776 x 510 mm</b>
Weight	<b>105 kg</b>
Payload	<b>130 kg / 250 kg</b>
Speed	<b>3 m / s</b>
Environment	<b>Indoor</b>
Enclosure class	<b>IP52 / IP64</b>
Autonomy	<b>6 / 12 h</b>
Batteries	<b>LiFePO<sub>4</sub> 15/30Ah@48VDC</b>
Traction motors	<b>4 x 500 W Brushless servomotors with safety brake</b>
Temperature range	<b>0° to +50°C</b>
Max. slope	<b>30 %</b>

### CONTROL

Controller	<b>Open architecture ROS Integrated CPU with Linux</b>
Communication	<b>WiFi 02.11a / b / g / n / ac Bluetooth 5.1 (5G/4G optional)</b>
Connectivity	<b>USB, RJ45, power supplies 12, 24 VDC and battery</b>