

RB-THERON

AUTONOMOUS MOBILE ROBOT (AMR)



DESIGNED FOR **INDOOR APPLICATIONS**

THE ROBOT CAN **CARRY 200 KG** & INTEGRATE DIFFERENT SENSORS

LOGISTICS
INDUSTRIAL TASKS
RESEARCH & DEVELOPMENT

OPTIONS
AUTOMATIC RECHARGING STATION
LIFTING UNIT



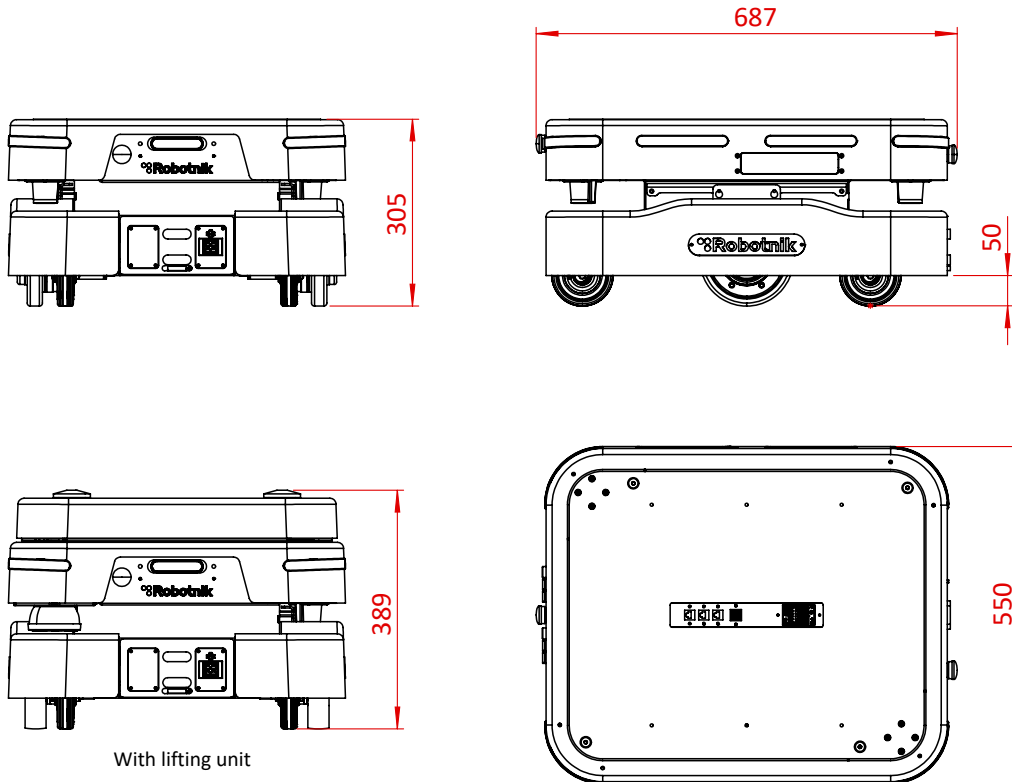

TECHNICAL SPECIFICATIONS

MECHANICAL

Dimensions	687 x 550 x 305 mm
Weight	45 Kg
Payload	200 Kg
Speed	1,25 m/s
Enclosure class	IP30
Autonomy	8 h (industrial use case)
Batteries	15Ah @ 48VDC
Temperature Range	0°C to + 40°C
Max. Slope	15 %
Traction system	Differential drive

CONTROL

Controller	CPU ROS (Intel i7)
Communication	WiFi 802.11ac (4G optional)
Connectivity	2 x USB, 2 x Ethernet and 1 x HDMI (lateral panel) 3 x Ethernet, 2 x USB and DC power output and signal pins (top panel)