

RB-I BASE

AUTONOMOUS MOBILE ROBOT (AMR)



INDOOR APPLICATIONS

THE ROBOT **CAN CARRY 50 KG**
& INTEGRATE DIFFERENT
SENSORS

LOGISTICS

INDUSTRIAL TASKS

RESEARCH & DEVELOPMENT

OPTIONS

AUTOMATIC RECHARGING STATION

LIFTING UNIT



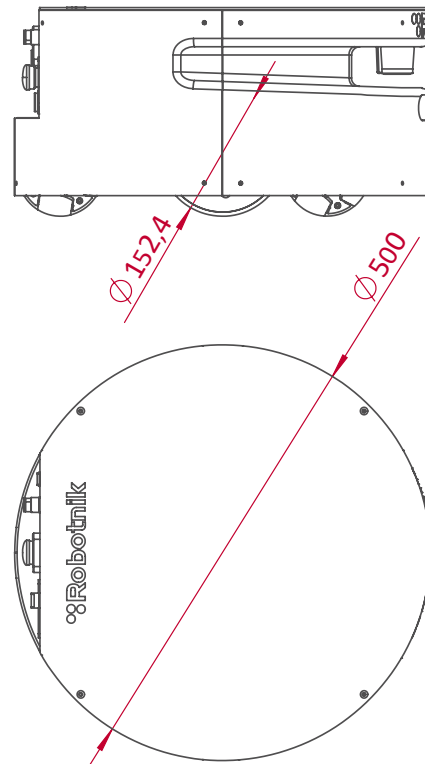
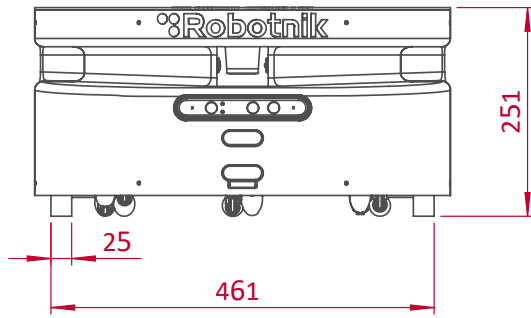

TECHNICAL SPECIFICATIONS

MECHANICAL

- Dimensions **∅ 500 x 251 mm**
- Dimensions **∅ 515 x 303-338 mm**
(with optional lifting unit)
- Weight **30 Kg**
- Payload **50 Kg**
- Speed **1,5 m/s**
- Enclosure class **IP51**
- Autonomy **6 h in industrial application**
- Temperature Range **0°C to +50°C**
- Max. Slope **8 %**
- Batteries **LiFePO₄ 30Ah@24V**
- Traction motors **2 x 250 W servomotors**
- Traction system **Differential drive**

CONTROL

- Controller **Open architecture ROS
Embedded PC with Linux**
- Communication **WiFi 802.11ac
4G**
- Connectivity **2 x USB, 1 x Ethernet, 1 x HDMI**